



# INSTRUCTION MANUAL

Butane Microtorch



Models: ST500 & ST1000

## ▲ DANGER

**This torch is used with a flammable product. Failure to comply with these Warnings and Instructions may result in an explosion or fire that may cause property damage, serious personal injury or death.**

Read and comply with the instructions and warnings in this manual and familiarize yourself with the torch before lighting and using. Review instructions and warnings periodically to maintain awareness. Do not try to operate before reading instructions.

EXTREMELY FLAMMABLE. CONTENTS UNDER PRESSURE.

- Take precautions not to heat fuel tank.
- Contains flammable gas under pressure. Do not expose the torch or fuel to temperatures exceeding 120°F/49°C or prolonged sunlight.
- Never use torch in or around flammable fumes, liquids, or explosive materials.
- Never pierce fuel tank or expose torch to fire.
- Do not breathe gas, fumes, vapor or spray. If inhaled, remove affected person to fresh air.
- Avoid contact with eyes or skin. In case of contact with eyes, rinse immediately with plenty of water and seek medical advice. For skin contact, flush with large amounts of water.
- Do not modify torch in any way. Do not alter factory settings. Serious injury or death can result from adjusting factory settings or modifying factory fitted parts. Always use manufacturer recommended replacement parts.
- Read and understand refueling instruction before refueling torch. Refueling the torch incorrectly can result in serious injury or death.

## ▲ WARNING

- Materials used in the construction of this device may contain brass (which may contain lead and cadmium) and the solder provided here contains lead, chemicals known to the State of California to cause birth defects or other reproductive harm.
  - Combustion by-products produced when using this device contain chemicals known to the State of California to cause cancer, birth defects, or other reproductive harm.
  - When used for soldering and similar applications, this product contains or produces chemicals known to the State of California to cause cancer and birth defects or other reproductive harm.
- 
- Keep torch out of reach of children and anyone who has not read instructions. Do not point torch towards face, other persons or flammable objects. Never attempt to use torch as a cigarette lighter
  - Always wear eye protection and gloves when lighting and using the torch.
  - To avoid risk of damage to torch, always protect torch from impact and never allow torch to drop onto floor or hard surfaces. Never use a torch that appears to be damaged.
  - Heating a surface may cause heat to be conducted to adjoining surfaces that may be combustible or become pressurized when heated. Always check to make sure no unintended parts or materials are being heated.
  - Do not use a leaking, damaged or malfunctioning torch. If torch is leaking, contact manufacturer or retailer.
  - Work only in well-ventilated areas. Avoid the fumes from fluxes, lead-based paint, and all metal heating operations. Be careful to avoid fumes from cadmium plating and galvanized metal- remove these coatings in the area to be heated by filing or sanding prior to heating.
  - Ignite torch away from face, hands, clothing, or other flammable material.
  - Extremely hot air escapes from exhaust ports on soldering tip assembly. Always rest torch on the stand supplied, even during short breaks, to avoid risk of damaging work surfaces or other flammable items. Extinguish torch during longer breaks. Never point exhaust ports toward eyes, face, hands, or other flammable items.

**DO NOT DISCARD THESE WARNINGS AND INSTRUCTIONS**

- Use caution when operating the torch outdoors on sunny or windy days. Bright sun makes it impossible to see the torch's flame. Wind may carry the torch's heat back towards you or other areas not intended to be heated. Windy conditions may also cause sparks to be blown into other areas with combustible materials.
- Burner nozzle and tip assembly become extremely hot during use and remain hot after extinguishing the torch. Take precautions not to touch torch tip until torch has cooled.
- Never use the torch on or near combustibles (fuels, rags, towels, paper products, etc.). Be careful around motor vehicles or any gasoline-fired products and beware of hidden fuel lines and tanks.
- Always make certain the torch is resting on the stand to reduce the risk of accidental tip over. Be sure the torch is not pointed in a direction which could cause nearby objects to ignite when the torch is set down.
- Never leave the torch unattended when lit.
- Never attempt to repair or heat a gasoline tank, a chemical drum an aerosol can, a compressed gas container that held flammable liquid or gas or any other chemical. Heating these is extremely dangerous, especially after they have been "emptied".
- Department of Transportation Hazardous Materials Regulations forbids the carriage of butane or other flammable gas products on passenger aircraft. Do not pack this item or any other flammable gas item in any checked or carry-on baggage.
- Make sure torch is completely extinguished after use.
- Ensure that torch is completely cool before storing.

**▲ CAUTION**

⚠ Exercise caution when using this device not to breathe vapors. Depending on the task being conducted with device (wood burning, melting plastic, etc.) toxic or nauseating vapors may exist.

**COMPONENTS**

**ST500**



**ST1000**

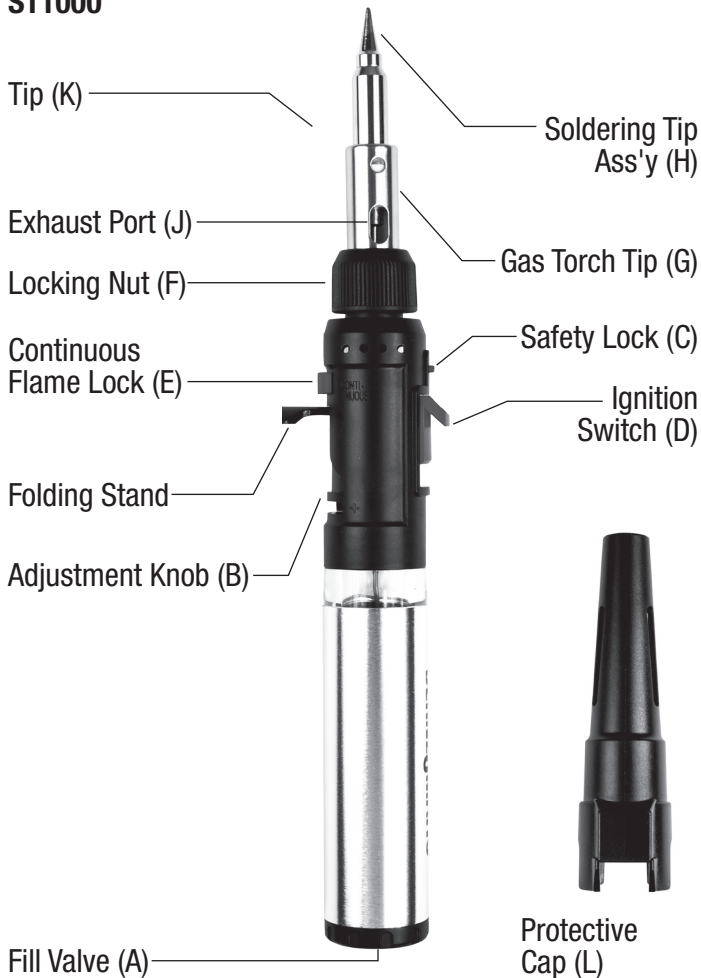

**DO NOT DISCARD THESE WARNINGS AND INSTRUCTIONS**

## REFILLING OPERATION

1. Use only Bernzomatic Butane fuel when refilling torch.
2. Ensure that the torch is extinguished before refilling.
3. Allow sufficient time for torch to cool to room temperature before refilling the torch with fuel.
4. Refill torch in a well-ventilated area free of fire or other sources of ignition and away from people.
5. Never smoke while refilling the torch.
6. Hold the torch with the FILL VALVE (A) up.
7. Invert fuel canister and insert the fuel canister tip into the FILL VALVE (A).
8. Push the fuel canister and torch together to allow fuel to flow into the torch fuel tank. Torch should be filled in about 10 seconds.
9. Stop refilling once the fuel begins to overflow.
10. Wait 3 minutes to allow fuel gas to stabilize before igniting the torch.

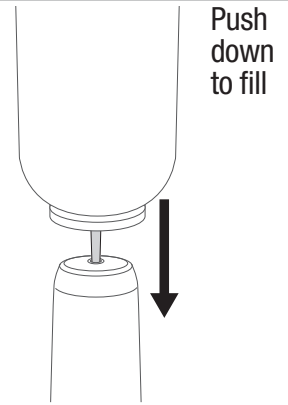

## LIGHTING AND OPERATION

### Intermittent use mode

1. Turn FLAME ADJUSTMENT KNOB (B) approximately halfway between (1) and (4) position.
2. Press the SAFETY LOCK (C) button down and slide the IGNITION SWITCH (D) away from burner tip.
3. Release IGNITION SWITCH (D) to extinguish torch.

### Continuous use mode

1. Turn FLAME ADJUSTMENT KNOB (B) approximately halfway between (1) and (4) position.
2. Press the SAFETY LOCK (C) button down and slide the ignition switch away from burner tip.
3. Slide CONTINUOUS FLAME LOCK (E) to "CONT" position to lock the IGNITION SWITCH (D) in the on position.
4. Release IGNITION SWITCH (D).
5. Slide the CONTINUOUS FLAME LOCK (E) to "OFF" position to extinguish the torch.

### ST1000 shown for reference



### Adjust flame

1. Slide FLAME ADJUSTMENT KNOB (B) to "1" for small flame.
2. Slide FLAME ADJUSTMENT KNOB (B) to "4" for large flame.

### Use as soldering iron

1. Torch is factory set for use as a soldering iron and can be used immediately.
2. Loosen LOCK NUT (F) and adjust the EXHAUST PORT (J) so that hot air escapes in a safe direction and does not damage work surface.
3. Tighten LOCK NUT (F) with firm pressure.
4. Ignite torch as shown above.

### Use as a hot air blower

1. Assemble for use as soldering iron.
2. Remove the TIP (K) from the SOLDERING TIP ASSEMBLY (H) by rotating the TIP (K) counterclockwise.
3. Torch is now ready for hot air blower operation.
4. Ignite torch as shown above.



**DO NOT DISCARD THESE WARNINGS AND INSTRUCTIONS**

## Use as a gas torch

(This is an open flame. Do not use with combustibles in the area. Read warning sections of instruction)

1. Assemble for use as hot air blower.
2. Unscrew LOCK NUT (F) and remove SOLDERING TIP ASSEMBLY (H) by dropping through bottom of GAS TORCH TIP (G).
3. Reinstall GAS TORCH TIP (G) and tighten LOCK NUT (F) with firm pressure.
4. Torch is now ready for gas torch operation.
5. Ignite torch as shown above.

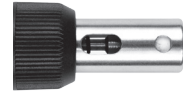

## Installing Protective Cap

1. Slide the PROTECTIVE CAP (L) firmly onto the torch LOCKING NUT (F).
2. Ensure that entire tip assembly is fully protected by cap.
3. Ensure that IGNITION SWITCH (D) is disabled by PROTECTIVE CAP (L).

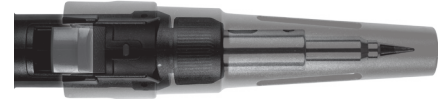

## ⚠ Additional Warnings

- Before each use, ensure that SOLDERING TIP LOCKING NUT (F) is securely tightened.
- Before each use and after refilling, listen for leaking. Never use a flame to check for leaks. Always use torch in a well-ventilated and spark-free area and where there are no open flames.
- In cold weather size of flame will be smaller. To produce larger flame, pre-warm torch to room temperature prior to use.

## STORAGE

1. Ensure that CONTINUOUS FLAME LOCK (E) is in the "OFF" position.
2. Release IGNITION BUTTON (D).
3. Allow several minutes for torch to cool.
4. Install PROTECTIVE CAP (L) firmly and ensure IGNITION SWITCH (D) is disabled.
5. When torch is cool, store torch out of reach of children.
6. Do not expose torch to temperatures in excess of 120°F/49°C.
7. Store torch in well ventilated areas.

**DO NOT DISCARD THESE WARNINGS AND INSTRUCTIONS**